

**Non-contact
temperature measurement
through flames from
200 °C to 1650 °C**

Features:

- Accurate temperature measurement through flames in the range from 200 °C to 1650 °C to monitor workpieces inside ovens (heated with fire), to measure inside chemical reactors and to observe the brick temperature in combustion chambers
- Double laser aiming marks real spot location and spot size up from 1.6 mm at any distance
- Optics 45:1 with selectable focus, compact sensor head size
- Usable up to 85 °C ambient temperature without cooling and automatic laser switch off at 50 °C
- Cooling and protection accessories for harsh environmental conditions



General specifications

Environmental rating	IP 65 (NEMA-4)
Ambient temperature ¹⁾	-20... 85 °C (sensing head, 50 °C with laser ON) -20 ... 85 °C (electronics)
Storage temperature	-40 ... 85 °C (sensing head) -40 ... 85 °C (electronics)
Relative humidity	10 – 95 %, non condensing
Vibration (sensor)	IEC 68-2-6: 3 G, 11 – 200 Hz, any axis
Shock (sensor)	IEC 68-2-27: 50 G, 11 ms, any axis
Weight	600 g (sensing head) / 420 g (electronics)

Electrical specifications

Outputs / analog	0/4 – 20 mA, 0 – 5 / 10 V, thermocouple J, K
Output / alarm	24 V / 50 mA (open collector)
Optional	Relay: 2 x 60 V DC / 42 V AC _{eff} ; 0.4 A; optically isolated
Outputs / digital	USB, RS232, RS485, CAN, Profibus DP, Ethernet (optional)
Output impedances	mA max. 500 Ω (with 8 – 36 V DC) mV min. 100 kΩ load impedance thermocouple 20 Ω
Inputs	Programmable functional inputs for external emissivity adjustment, ambient temperature compensation, trigger (reset of hold functions)
Cable length	3 m (standard), 8 m, 15 m
Power Supply	8 – 36 V DC
Current draw	Max. 160 mA
Laser 635 nm	1 mW, ON/OFF via electronic box or software

Measurement specifications

Temperature range (scalable via programming keys or software)	200 ... 1450 °C (MT) 400 ... 1650 °C (MTH)
Spectral range	3.9 μm
Optical resolution (90 % energy)	45:1
System accuracy (at ambient temp. 23 ± 5 °C)	± 1 % ^{2) 3)}
Repeatability (at ambient temp. 23 ± 5 °C)	± 0.5 % or + 0.5 °C ³⁾
Temperature resolution (digital)	0.1 K
Exposure time ⁴⁾ (90 % signal)	10 ms
Emissivity/ Gain (adjustable via programming keys or software)	0.100 – 1.100
Transmissivity/ Gain (adjustable via programming keys or software)	0.100 – 1.100
Signal processing (parameter adjustable via programming keys or software, respectively)	Peak hold, valley hold, average; extended hold function with threshold and hysteresis
Software	optris® Compact Connect

¹⁾ The functioning of the LCD display may be limited in ambient temperatures below 0 °C

²⁾ For object temperatures above >300 °C

³⁾ ε = 1, response time 1 s

⁴⁾ With dynamic adaptation at low signal levels

Optical specifications

Chart SF optics, D:S = 45:1

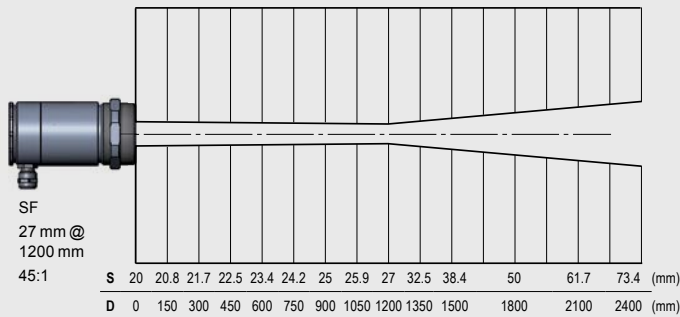

Further optics, D:S = 45:1

... SF	27 mm @ 1250 mm
... CF1	1.6 mm @ 70 mm
... CF2	3.4 mm @ 150 mm
... CF3	4.5 mm @ 200 mm
... CF4	10 mm @ 450 mm

Dimensions

Sensing head

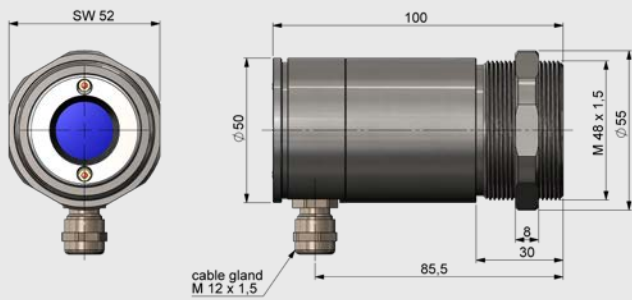

Electronics

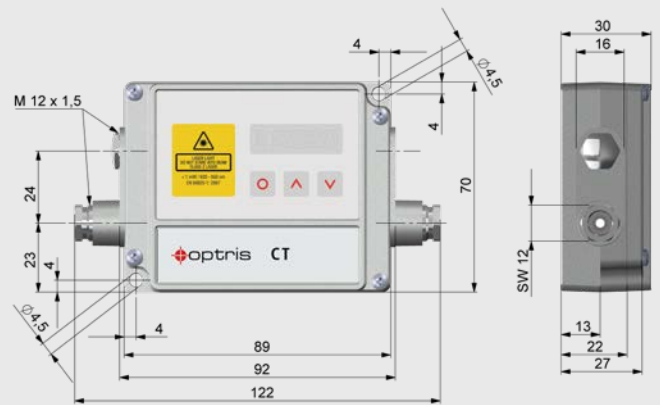

Accessories (examples)

Mounting angle, adjustable
in two axes (ACCTLAB)



Cooling housing
(ACCJCTL)



Mounting angle for cooling housing,
adjustable in two axes (ACCJAB)



Water cooling and air purge for
sensing head (ACCTLW + ACCTLAP)



Mounting device for cooling housing
(ACCLRm)

